

# PRODUCT GUIDE

## MEGA

1200 / 1500 / 1800 / 2200

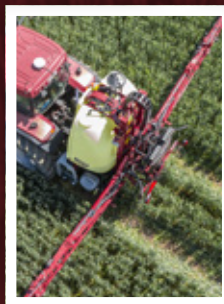
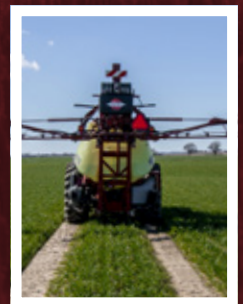

# Table of Content

Welcome to the Product guide . . . . .	3
MADE FOR FARMING	
Specialist Solution for Daily Work. . . . .	4
WorkZone. . . . .	5
<b>Chassis</b>	
Frame . . . . .	6
3-point linkage – coupling . . . . .	7
Service area . . . . .	8
Boom lift . . . . .	9
Main tank. . . . .	10
RinseTank. . . . .	11
CleanWater tank . . . . .	11
<b>Fluid system</b>	
Fluid diagram – MEGA basic. . . . .	12
Fluid diagram with optional extras . . . . .	13
Manifold valves . . . . .	14
HARDI diaphragm pump . . . . .	15
EasyClean filter . . . . .	16
CycloneFilter . . . . .	17
TurboFiller . . . . .	18
EFC boom section valves . . . . .	19
DynamicFluid4 . . . . .	20
<b>Electronics</b>	
SmartCom electronic platform . . . . .	22
HARDI ServiceTool. . . . .	23
Grip and SetBox. . . . .	24

<b>Booms</b>	
PRO VHZ 15-18 m . . . . .	25
VPZ 20-28 m . . . . .	25
VPZ Boom Suspension. . . . .	26
VPZ boom wings 20-28 m. . . . .	27
PRO boom wings . . . . .	28
Z boom hydraulics. . . . .	29
Y boom hydraulics. . . . .	30
Boom sections . . . . .	31
Boom management systems. . . . .	32
FrontTank solution . . . . .	33
<b>Optional extras</b>	
PumpFill . . . . .	34
External cleaning kit. . . . .	35
BoomPrime . . . . .	36
DilutionKit. . . . .	36
End-nozzle kit. . . . .	37
SafetyLocker . . . . .	38
HARDI 464 pump . . . . .	39
InLine Filters . . . . .	39
Transport wheels . . . . .	40
Boom Lights . . . . .	40
HC 7500, HC 8600, HC 9600 . . . . .	41
AirRide suspension . . . . .	41
Nozzles . . . . .	42
<b>HARDI Service</b>	
HARDI Service. . . . .	43
<b>Specifications</b>	
Technical specifications . . . . .	44

# Welcome to the Product guide

WELCOME



## Value for Money, Ease of Use, Safety, Reliability and Quality

These values are the cornerstones in development of a new HARDI product. And they are also the cornerstones in design of the MEGA lift mounted generation.

In the present Product guide you will find well-known and well-proven features. As you will see, new features have been developed to bring the MEGA in the top position of lift mounted sprayers. The 2200 I is biggest lift mounted model in the market.

Value for Money – the sprayer should be long lasting, meeting the farmers' present and future demands, so that also in 5 years' time, they would have a modern looking product of favorable trade value even as a second hand machine.

Ease of Use – the sprayer must work without too much concentration of small details. Farmers would like a well-equipped sprayer that is easy to operate and allows for quick filling and cleaning, just as it should offer all the features of a modern sprayer.

Safety – the sprayer should be easy to use with a high safety standard for the operator as well as for the environment.

Reliability and Quality – the sprayer should be of a high overall reliability and quality, meaning high quality materials, good design and excellent finish.

The MEGA is HARDI's answer to the demands of this customer segment, but how should the farmer know what choices and opportunities he has? Here we need you as a sales expert to tell him what the MEGA has to offer.

The MEGA will be introduced in several steps – this Product guide shows the status today.

With this Product guide you have a marketing tool that goes far more into the depth with the technical argumentation than brochure material. Possibly, use the Product guide in order to get full benefit and the most satisfactory introduction to the MEGA.

Enjoy yourself!

## Confidential

This is your personal sample of the MEGA Product guide and should be used as your personal sales tool – please treat it confidentially.

Date: \_\_\_\_\_

Signature: \_\_\_\_\_



# MADE FOR FARMING

## Specialist Solution for Daily Work

### Value for Money

- ▶ Part of the HARDI functional design
- ▶ HARDI pumps 364 and 464
- ▶ AirRide suspension
- ▶ Strong chassis
- ▶ Heavy-duty
- ▶ High tensile steel
- ▶ High speed tested
- ▶ Fast regulation DynamicFluid4 fluid system
- ▶ Surface treatment and high paint quality
- ▶ Competitive price
- ▶ High resale value
- ▶ HARDI is a global company

### Ease of use

- ▶ Logic WorkZone with manifold valves
- ▶ CycloneFilter
- ▶ Electronics with LogicMenu
- ▶ SetBox and Grip
- ▶ HC 7500
- ▶ HC 8600
- ▶ HC 9600
- ▶ SmartCom ISOBUS
- ▶ Full integration in the high-end terminals
- ▶ AutoSectionControl
- ▶ AutoSlant

### Safety

- ▶ Excellent centre of gravity
- ▶ RinseTank located on right side in a low position
- ▶ EasyClean suction filter
- ▶ BoomPrime System
- ▶ Easy coupling Category 2 and Category 3 solution – tractor link-arms are guided into correct position
- ▶ Integrated storage wheels
- ▶ Perfect solution to park the sprayer

### Reliability and Quality

- ▶ TurboFiller – high capacity – easy chemical filling
- ▶ Boom alternatives: VPZ 20-28 m, PRO 15-18 m
- ▶ Tested to spray at 20 km/h
- ▶ FrontTank – easy way to increase capacity
- ▶ Know-how as sprayer specialist
- ▶ Accredited final test



# WorkZone



The MEGA has been designed with a strong focus on user-friendliness and ease of operation, the WorkZone is a fine example of this. In this area, everything you need to operate the sprayer is available, with all primary functions placed in easy to reach positions and everything designed to be simple and logical to operate.

The SafetyLocker is placed in the WorkZone.

#### Left side of WorkZone

1. Manifold valve – pressure
2. Agitation valve
3. Manifold valve – suction
4. PumpFiller coupling
5. TurboFiller
6. TurboFiller operating unit
7. Cyclone pressure filter
8. SafetyLocker
9. Pressure regulation valve – DynamicFluid4
10. Pressure empty coupling

#### Right side of WorkZone

11. EasyClean suction filter
12. RinseTank

#### Front of WorkZone

13. CleanWater tank

CUSTOMER BENEFITS:

- ▶ **Domex steel:**
  - Strength
  - Save weight
- ▶ Laser cut tubing
- ▶ CNC bending
- ▶ Robot welding
- ▶ Excellent crop clearance
- ▶ Centre of gravity close to tractor

# Frame

The heavy-duty MEGA chassis is built in high-tensile steel, ensuring exceptional strength.

The chassis is built to endure also under difficult conditions as rough tracks and high driving speed.

### Centre of gravity

The centre of gravity is close towards the tractor.

### Clearance – flat underneath

The MEGA chassis has a flat underside to avoid crop damage when working in higher crops. The

storage wheels can be folded in by a remote system.

### Excellent crop clearance

MEGA without compromising the clearance under the sprayer.

The 2 chassis versions are different in length – the small 1200 / 1500 l is 10 cm shorter than the 1800 / 2200 l.

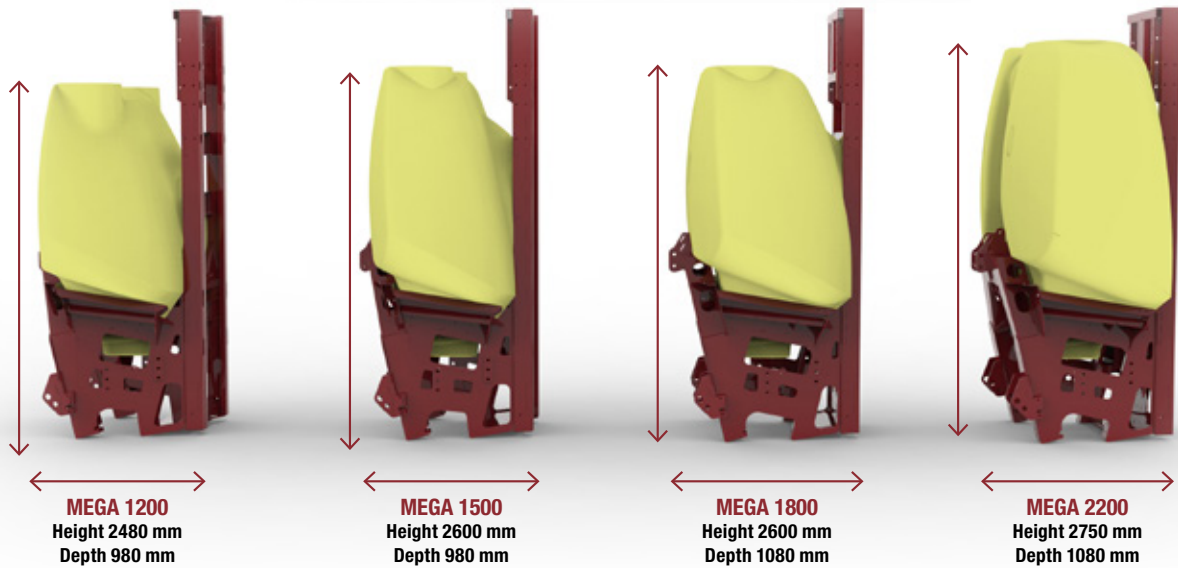
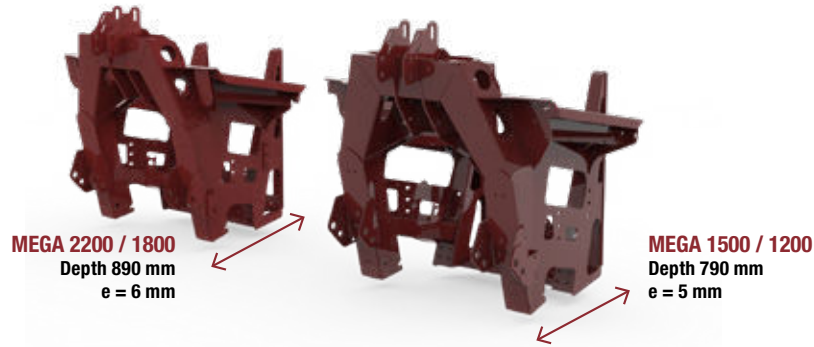

## 3-point linkage – coupling

### The MEGA can be delivered with category 2 and 3 linkage

The coupling bar can be easily fitted to the lower linkage of the tractor before driving backwards to couple the sprayer safe and easy.

### The optional AirRide suspension

Air dampers will absorb movements of the sprayer. The dimensions of the air dampers ensure that they

do not get over-compressed when the tank is full, which will make them last longer.

During road transport the MEGA and consequently the boom will be less stressed.

In field conditions the boom suspension will work better. This way the boom can be run in optimum height over the crop.

#### CUSTOMER BENEFITS:

- ▶ AirRide suspension gives less boom movements
- ▶ Category 2 and 3
- ▶ Fast and easy to connect
- ▶ Storage wheel integrated

CHASSIS





CUSTOMER BENEFITS:

- ▶ Safety locker with two boxes on the left side,
- ▶ Fold able ladder on right hand side

## Service area

### Ladder on right hand sight

A two times flowed ladder on the right hand will be standard on all MEGA M in this version of the product guide the photo show the prototype ladder.

The lid is located close to the latter, on the right side, allowing easy inspection of the tank from the ladder. The design of the tank gives the operator excellent visibility of the sides as well as the bottom of the tank.

### Access to electronic system on center section or behind CleanWater tank

To aid in service accessibility the majority of electronic components and connections are located in a box behind the main tank. Well protected. Further ECU s are on the centre of the boom.

### Easy access to fluid system

Excellent service access to the fluid system e on the left side can be easy reached by taking the shields away. The suction filter is on the right hand side easy to reach. The pressure filter is on the left side behind the Manifold system

### Protected placement of gauges

The pressure gauge is integrated in the hand wash tank design.

### SafetyLocker

A SafetyLocker on the left side for storage of gloves and mask close to the WorkZone.



# Boom lift

The XL boom lift of MEGA with PRO and VPZ booms allows a boom height adjustment of 160 cm, allowing working heights between 50 cm and 210 cm.

The frame has a total height of 295 cm.

### Hydraulic lift suspension.

The lift works with a cylinder with a 80 cm movement, the lifting range is reached due to a reflection role – so the lift will react faster, and in combination with AutoSlant give you a more smooth operation.

### Optimum boom position in transport

An indication arrow helps to fold in the best height position. When folding in transport the boom is guided in the correct position by different brackets and sliding plates. The boom is not hanging on the

transport brackets it is always supported by the hydraulic dampened lift cylinder.

On VPZ strong secure-pins take care that the boom wings stay in position during transport.

### Hose guidance package

A hose guidance package over the lift in combination with the integrated fluid channel, between the RinseTank and main tank secures a perfect hose and wire protection.

#### CUSTOMER BENEFITS:

- ▶ **Flexible height adjustment:**  
Down to 50 cm  
Up to 210 cm
- ▶ **XL lift width:**  
80 cm
- ▶ **1 single acting cylinder**

CHASSIS





## CUSTOMER BENEFITS:

- ▶ **Material:**  
UV protected polyethylene
- ▶ **Material thickness:**  
min. 11 mm
- ▶ **Volume Nominal/ Maximum:**  
1200 l / 1350 l  
1500 l / 1630 l  
1800 l / 1950 l  
2200 l / 2380 l
- ▶ **Centre of gravity close to front**
- ▶ **Efficient agitation**
- ▶ **Easy to clean**
- ▶ **Uniform weight distribution**
- ▶ **Deep sump**
- ▶ **Large contact area to the chassis**

## Main tank

The polyethylene tanks of the MEGA are produced as one part. They have a very flat surface, no inside walls, and they rest freely in the frame on a large contact area. To make the sprayer as stable as possible, the tank is completely integrated in the frame design and is fully supported by the frame. This also ensures low centre of gravity.

Centre of gravity close to the tractor When designing the tank, a major challenge was to get the centre of gravity close to the tractor.

### Efficient agitation

The agitation is made by a 4 Venturi nozzles. The nozzles are positioned to give optimal agitation everywhere in the tank. The output of the Venturi nozzles are around 4 times the input, meaning 280 l/min agitation with an input of only 70 l/min. Less use of pump capacity means more capacity available for spraying.

### Deep central tank sump

The sprayer is completely emptied even on slopes up to 10 degrees – uphill or downhill.

### Easy to clean inside and outside

The smooth surface of the tank makes the MEGA very easy to clean.

Easy to rinse inside with the tank rinsing nozzles.

100% of the tank can be “seen” by the rinsing nozzles. No sharp corners prevent sedimentation of pesticide.

### TankGauge electric level indicator

The MEGA can be equipped with a TankGauge. The tank volume is shown on the terminal display.





# RinseTank

The 170 l RinseTank is placed on the right hand side. The RinseTank is large – always more than 11% of the main tank capacity to have adequate liquid for both inside and outside cleaning.

Easy filling from the WorkZone with 1" filling connector as standard.

The RinseTank is typically the last tank to be emptied, and its position close to the tractor gives the best weight distribution.

## Rinsing nozzle

Together with the RinseTank a high capacity rinsing nozzles is delivered as standard.



### CUSTOMER BENEFITS:

- ▶ The RinseTank is placed on the right hand side.
- ▶ Capacity 170 l
- ▶ Material: UV protected polyethylene
- ▶ Material thickness is 9 mm

CHASSIS

# CleanWater tank

## CleanWater tank for hand washing

The 20 l CleanWater tank is mounted in the front of the main tank.

The tank is also the carrier for the pressure gauge and the bracket for the level indicator of the main tank.

The tank can be taken away to get access to the front SmartCom ECU, when fitted.

The emptying valve is placed in the work zone close to the TurboFiller.



### CUSTOMER BENEFITS:

- ▶ Placed in front of the main tank.
- ▶ Capacity 20 l
- ▶ Material: UV protected polyethylene
- ▶ Filling from work zone
- ▶ Carries pressure gauge and tank level indicator
- ▶ Covers front SmartCom



# FLUID SYSTEM

## Fluid diagram – MEGA basic

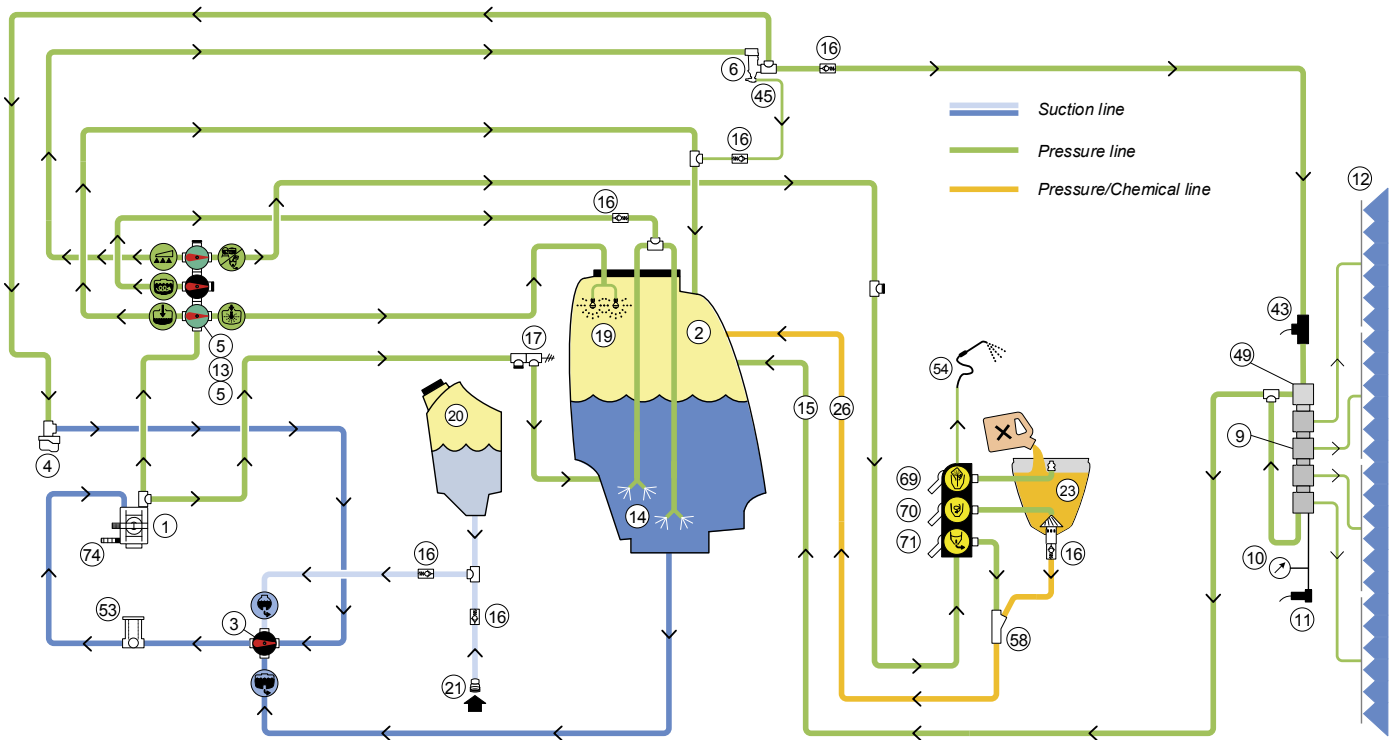

- |   |                                     |   |
|---|-------------------------------------|---|
| <b>1</b> Pump                                       | <b>13</b> Agitation Valve           | <b>43</b> Flowmeter                     |
| <b>2</b> Main Tank                                  | <b>14</b> Agitation nozzles         | <b>45</b> Boost Valve                   |
| <b>3</b> Suction Valve                              | <b>15</b> Return Line for Main Tank | <b>49</b> Bypass Valve                  |
| <b>4</b> DynamicFluid4<br>Pressure Regulation Valve | <b>16</b> One-Way Valve             | <b>53</b> EasyClean Filter              |
| <b>5</b> Pressure Valve                             | <b>17</b> Safety Valve              | <b>54</b> Cleaning pipe for TurboFiller |
| <b>6</b> CycloneFilter                              | <b>19</b> Rinsing Nozzles           | <b>58</b> Ejector                       |
| <b>9</b> EFC boom section valves                    | <b>20</b> Rinse Tank                | <b>69</b> TurboFiller Cleaning Valve    |
| <b>10</b> Pressure Gauge                            | <b>21</b> Rinse Tank Coupler        | <b>70</b> TurboFiller Deflector Valve   |
| <b>11</b> Pressure Sensor                           | <b>23</b> TurboFiller               | <b>71</b> TurboFiller Suction Valve     |
| <b>12</b> Spray Boom                                | <b>26</b> Tank Hose for TurboFiller | <b>74</b> Speed Sensor for Pump         |

# Fluid diagram with optional extras

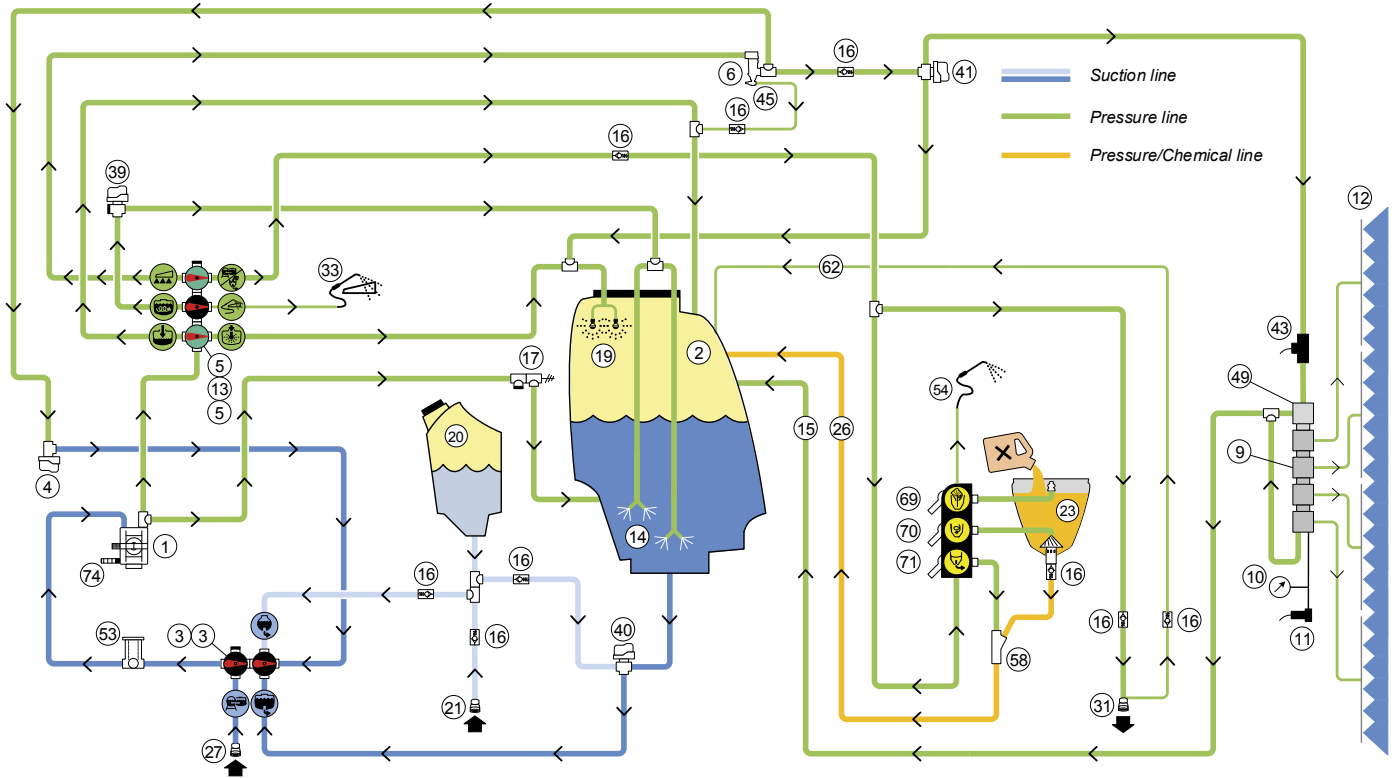





- |   |   |   |
|---|---|---|
| <b>1</b> Main Pump                                  | <b>16</b> One-Way Valve                   | <b>41</b> Dilution Valve, Rinsing       |
| <b>2</b> MainTank                                   | <b>17</b> Safety Valve                    | <b>43</b> Flowmeter                     |
| <b>3</b> Suction Valve                              | <b>19</b> Rinsing Nozzles                 | <b>45</b> Boost Valve                   |
| <b>4</b> DynamicFluid4<br>Pressure Regulation Valve | <b>20</b> RinseTank                       | <b>49</b> Bypass Valve                  |
| <b>6</b> CycloneFilter                              | <b>21</b> RinseTank Coupler               | <b>53</b> EasyClean Filter              |
| <b>9</b> EFC boom section valves                    | <b>23</b> TurboFiller                     | <b>54</b> Cleaning pipe for TurboFiller |
| <b>10</b> Pressure Gauge                            | <b>26</b> Tank Hose for TurboFiller       | <b>58</b> Ejector                       |
| <b>11</b> Pressure Sensor                           | <b>27</b> PumpFill coupler                | <b>62</b> Pressure Relief Line          |
| <b>12</b> Spray Boom                                | <b>31</b> Pressure Empty                  | <b>69</b> TurboFiller Cleaning Valve    |
| <b>13</b> Agitation Valve                           | <b>33</b> Spray Gun for External Cleaning | <b>70</b> TurboFiller Deflector Valve   |
| <b>14</b> Agitation nozzles                         | <b>39</b> Dilution Valve, Pressure        | <b>71</b> TurboFiller Suction Valve     |
| <b>15</b> Return Line for Main Tank                 | <b>40</b> Dilution Valve, Suction         | <b>74</b> Speed Sensor for Pump         |





## CUSTOMER BENEFITS:

- ▶ **Easy to operate**
- ▶ **Multifunctional**
- ▶ **Convenient location**
- ▶ **User-friendly icons**

**Pressure**

-  Spraying
-  PressureEmpty/  
TurboFiller use
-  Agitation
-  External cleaning
-  Filling
-  Tank cleaning
-  Filling port RinseTank

**Suction**

-  Suction from  
external source
-  Suction from  
external source
-  Suction from  
main tank

# Manifold valves

All primary functions needed to operate the sprayer when filling chemicals or cleaning have been built into two suction and three pressure valves. These valves are located in the working zone on the left side.

The logically placed handles and the easy-to-read colour-coded icons make the system very easy to understand and operate and greatly reduce the start-up and operation time of the sprayer.

If an optional filling system is added it is always combined with a pressure empty device.

If an optional FrontTank is added, an extra valve will be added.



# HARDI diaphragm pump



## CUSTOMER BENEFITS:

- ▶ Easy to operate
- ▶ Multifunction
- ▶ Convenient location
- ▶ User-friendly icons

FLUID SYSTEM

The MEGA liquid system is driven by the robust grease-lubricated HARDI diaphragm pump.

### Self-priming

The pump is self-priming and will in all start-up conditions be able to prime the filling and spraying system.

### Open crankcase

The unique HARDI pump has an open crankcase. This ensures that the crankcase will not hold any chemicals, thereby avoiding fast destruction of the bearings and the crankshaft in case of an unlikely diaphragm failure.

### Able to run dry without damage

The HARDI pump can run completely dry without any damage at all. No liquid for cooling is needed.

### Easy service pump

The pump is mounted on the rear to a specific bracket. Diaphragms and valves can be changed without taking out the pump. New greasing system.

### No contact between chemicals and moving mechanical parts

All moving parts are completely separated from the liquid running through the pump.

The pump transmission is either done with a standard PTO or with an optional wide angle PTO shaft.

## Pumps available for the MEGA

Pump	r/min	Stroke	Capacity at 0 bar
364	540	9.0 mm	194 l/min
464	540	10.0 mm	280 l/min





## CUSTOMER BENEFITS:

- ▶ Easy to clean
- ▶ Dirt trap
- ▶ Auto shut-off
- ▶ Surface area 581 cm<sup>2</sup>
- ▶ Flow capacity 450 l/min
- ▶ Inlet diameter 2½"
- ▶ Outlet diameter 2½"
- ▶ Screen size:  
30 mesh std.  
50 mesh  
80 mesh

## EasyClean filter

The HARDI EasyClean suction filter is a high capacity filter with a very large filter surface. The condition of the filter can be constantly monitored on an external gauge. This ensures that the filter is cleaned when needed and only when needed. The filter is placed behind the cover on the right side of the MEGA and can easily be checked from the ground.

When opening the lid, the main valve is automatically turned to OFF.

The automatic shut-off valve ensures safe operation of the sprayer, without any risk of spill.

The condition of the filter can be monitored on the vacuum gauge.

The unique vacuum gauge ensures that the filter is cleaned when needed and only when needed.

Two flaps inside the filter ensure that impurities sustained will be removed when the screen is pulled out.

### Very high capacity system

The filter has a large screen surface ensuring high capacity.

The filter is fitted in an upright position behind the right side cover.

The filter is fitted in such a position that it can be serviced from the ground, without any risk of spill.

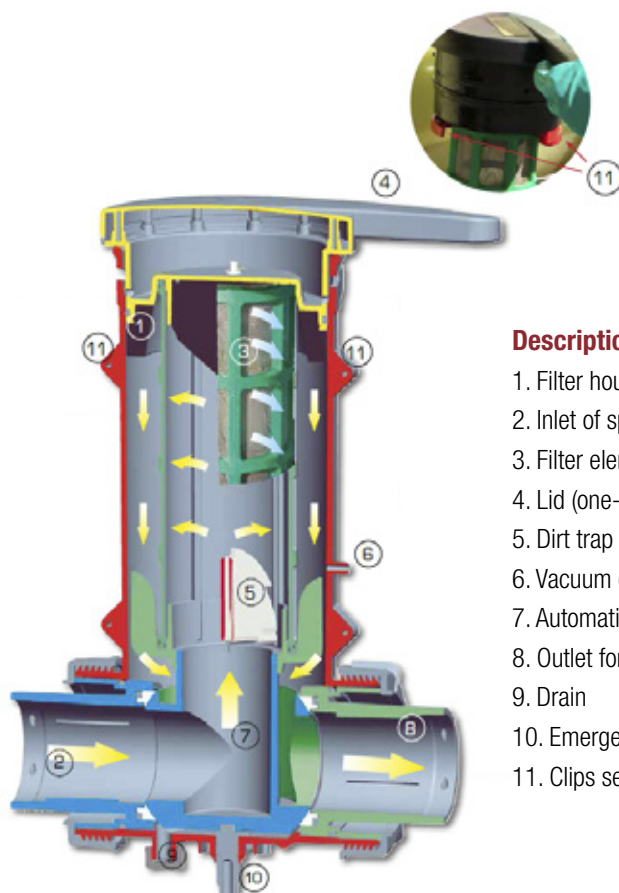

### Description of elements:

1. Filter housing
2. Inlet of spray liquid
3. Filter element
4. Lid (one-hand operation)
5. Dirt trap flaps
6. Vacuum gauge line for monitoring flow
7. Automatic ON/OFF valve
8. Outlet for liquid
9. Drain
10. Emergency operation
11. Clips securing the filter insert



# CycloneFilter

The HARDI CycloneFilter is a unique self-cleaning pressure filter that uses a high-speed cyclone for additional cleaning action. The cyclone action increases the cleaning capacity of the filter significantly. This ensures fewer stops and reduced pressure loss in the liquid system. Furthermore, the HARDI CycloneFilter has a unique boost function that allows the filter to be flushed "on-the-go" when needed.

Unique cyclone action greatly improves the self-cleaning action.

The cyclone created inside the filter increases the speed of the liquid against the filter screen, thereby increasing the efficiency of the self-cleaning action.

The filter is fitted in an upright position, meaning that spill can be avoided when inspecting the filter.



## CUSTOMER BENEFITS:

- ▶ **Flow capacity:** 400 l/min
- ▶ **Inlet diameter:** 1½"
- ▶ **Outlet diameter:** 1½"
- ▶ **Screen size:** 80 mesh std.
- ▶ **Available as spare parts:** 50 mesh  
100 mesh

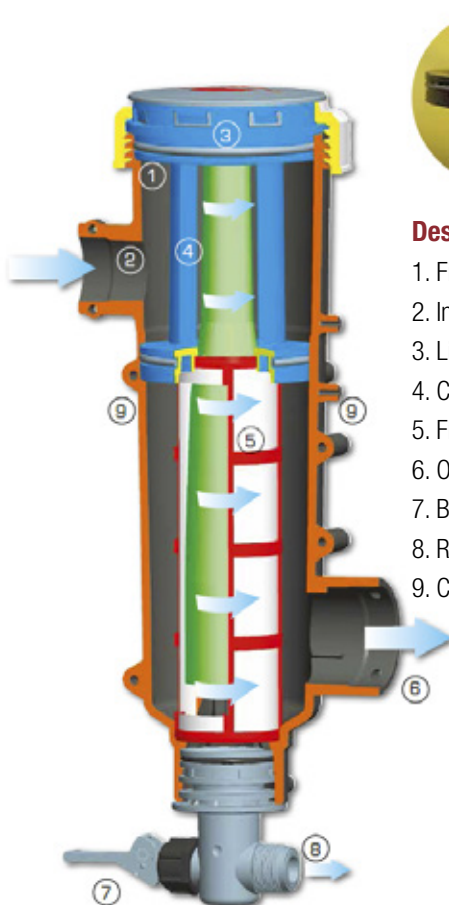

## Description of elements:

1. Filter housing
2. Inlet of spray liquid
3. Lid (one-hand operation)
4. Cyclone chamber
5. Filter element
6. Outlet of spray liquid
7. Boost valve
8. Return line
9. Clips securing the filter insert

## CUSTOMER BENEFITS:

- ▶ Filling capacity of liquid up to 120 l/min
- ▶ Size of hopper: 25 l
- ▶ Effective TurboDeflector
- ▶ Container rinse
- ▶ Cleaning pipe

## TurboFiller

The HARDI TurboFiller is standard on MEGA and is developed to handle large quantities of powders and liquids. Its high capacity is achieved through a combination of high vacuum and liquid rotation produced by a TurboDeflector inside the hopper.

### High mixing capacity

Liquid at high pressure is being used to create a powerful rotation inside the hopper. The rotational movement powerfully mixes powders and liquids as they are drawn into the sprayer.

The highest capacity is achieved when the TurboFiller is more than half-filled with water.

### Optimum filling height

The TurboFiller is easily operated with 3 valves:

- ▶ Container rinse
- ▶ TurboDeflector with liquid in ON/OFF
- ▶ TurboFiller ON/OFF

### Very high vacuum and suction capacity

A large external ejector system creates a powerful vacuum that transfers powders and liquid directly into the tank.

### Lance for cleaning

A cleaning lance is fitted as standard on the TurboFiller. This trigger valve with 1 m hose can be used for flushing the hopper or filling liquid into a container.





# EFC boom section valves



## CUSTOMER BENEFITS:

- ▶ Pressure drop at 120 l/min: 1.6 bar
- ▶ Manifold diameter: 19 mm
- ▶ Fast nozzle ON/OFF
- ▶ Easy service
- ▶ Fast thorough decontamination
- ▶ Increased flow capacity Fluid system

FLUID SYSTEM

The ElectricFastControl (EFC) is a modular system with a positive drive motor valve for each section and a single pressure dump valve, when all sections are switched to OFF.

The section valves incorporate a pressure dump. When the section is switched to OFF, the pressure in the line to the nozzles is relieved.

This results in instant shut-off at the nozzles. The EFC does not need any form of adjustment, e.g. pressure equalization.

Fast nozzle OFF, even with very small capacity nozzles.

Incorporated pressure dump insures instant nozzle closure.

High flow capacity.

Larger diameter manifold to handle high application rates and larger boom widths.

### Flowmeter

The flowmeter is on all MEGA standard and mounted in the middle of the section valves.

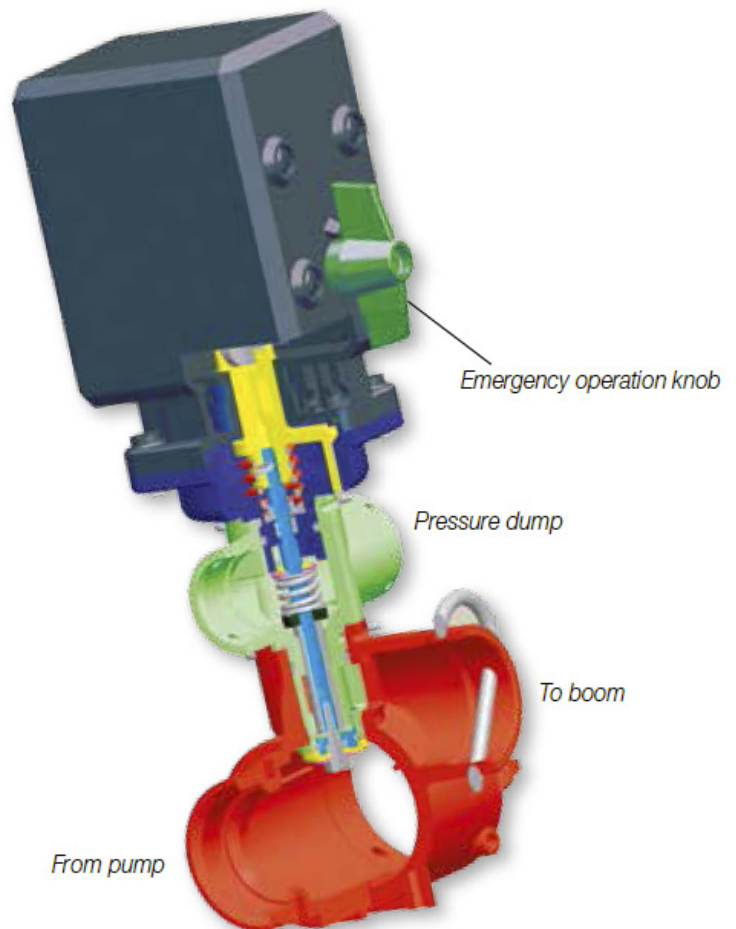



## CUSTOMER BENEFITS:

- ▶ Fast reaction
- ▶ High precision
- ▶ Self calibration
- ▶ 4 sensors for maximum precision



# DynamicFluid4

## Dynamic fluid system based on 4-sensor technology

### Fast and precise regulation

With precision and capacity in mind, HARDI challenged the traditional way of regulating volume rate. Traditionally, a sprayer applies and then measures actual volume rate. When the rate applied and the volume rate do not match the pre-set volume, the computer system will regulate until they match.

This conventional spray systems means that driving speed, boom width and pump revolutions must stay relatively stable to obtain a precise regulation.

With today's modern tractor transmissions, powerful engines, advanced boom suspensions and GPS controlled spray booms, the conventional way of

spraying has changed. These improvements in tractor and sprayer technology have now made the liquid regulation the weak part of the application system. Now that the control of the boom and tractor is optimized by technology, the operator demands more from the application system.

DynamicFluid4 is the solution for these challenges. In this chapter the technique and the benefits of the system are described.

The fast reaction is proven in different tests – the EN/ISO 16119 standard demands a 10% accuracy by speed or volume rate changes in 7 seconds. The DF4 system reaches the +/-10% value after 3.5 seconds, after 7 seconds the accuracy is +/- 0.5%.

## Technique

**Input to the regulation system comes from 6 different sources.**

### Two are outside the fluid system:

#### 1. Active boom width.

The boom is set up with a number of sections and size of each section.

As boom sections are turned ON/OFF, the active boom size is monitored based on each boom section.

#### 2. Driving speed.

Speed input is required to know how fast the sprayer is travelling (GPS input or wheel sensor)

### Four sensors are in the fluid system, 4 in DynamicFluid4, refer to these 4 sensors:

**3. Pump rpm.** Measured by sensor on the pump. PTO speed can vary, affecting the pump output. Tractor acceleration does not necessarily mean higher revolutions on the PTO and vice versa. Reading pump RPM means that the system knows the pump flow output.

#### 4. Regulation valve position.

An angle sensor (Hall sensor) is mounted internally and reads the disk in the regulation valve. The sensor is used to know the position of the valve.

#### 5. Flowmeter.

Measures flow going to the boom.

#### 6. Pressure sensor.

Measures the pressure in the fluid system at the EFC before going to the boom.

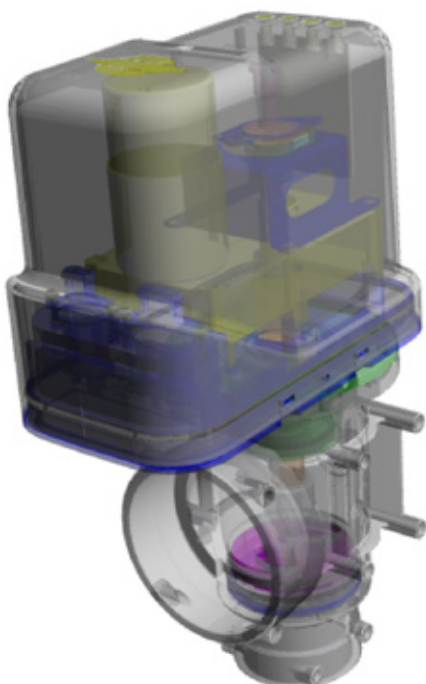

## Examples

### Increase in speed

After completing a turnout of the headland, the sprayer can quickly accelerate from 6 to 12 km/h in the first 30 m. With a traditional system the volume rate will be held against the driving speed and corrected. When accelerating, the new set-point will already be too low and next feedback will have same result. This will continue, too, after the acceleration has stopped, and first measure hereafter will give the right feedback for the regulation. Not until the stable speed has been obtained, the feedback will be correct, and the last correction can be made. In this example the whole area sprayed during the acceleration and until the last correction after the acceleration has been underdosed.

By use of the DynamicFluid4 (Patent Pending) and feed-forward, the system will react directly on the speed change and not wait until the speed change has developed to an underdose.

### Stability and safety

More sensors often mean bigger risk of failure, and consequently more downtime. The sensors in DynamicFluid4 each have their individual task, but they will also work as back up for each other. That means that if one sensor fails, calculation will continue with signals from the remaining sensors, and the regulation will continue. This goes for pump rpm, flow and pressure sensors.

Two inputs are vital for the automatic regulation. If one of the signals driving speed or position of regulation valve is missing, regulation has to be done manually.

If a signal is missing, the driver will get a warning on the display.

### SoftStart

When the tank gets empty at the end of a spray job, the regulation will try to compensate by closing the regulation valve. If the driver forgets to turn down the pressure manually, this will be the set-point when starting on the next full tank. The result is a pressure peak in the system, which in some cases could cause damage to the system potentially resulting in leaks. DynamicFluid4 has a (customer set) standby pressure which will be the maximum pressure when starting, thereby avoiding to have these unintended pressure peaks in the system.

As DynamicFluid4 is working with flowmeter and pressure sensor, the high accuracy can be obtained even with output rates less than 15 l/min. In contrast to conventional flowmeter based regulation, pressure sensor and flowmeter input ensure same high accuracy in the entire flow range.

#### CUSTOMER BENEFITS:

- ▶ Capacity is 500 l/min at 1 bar
- ▶ LED indicator lights for diagnostics

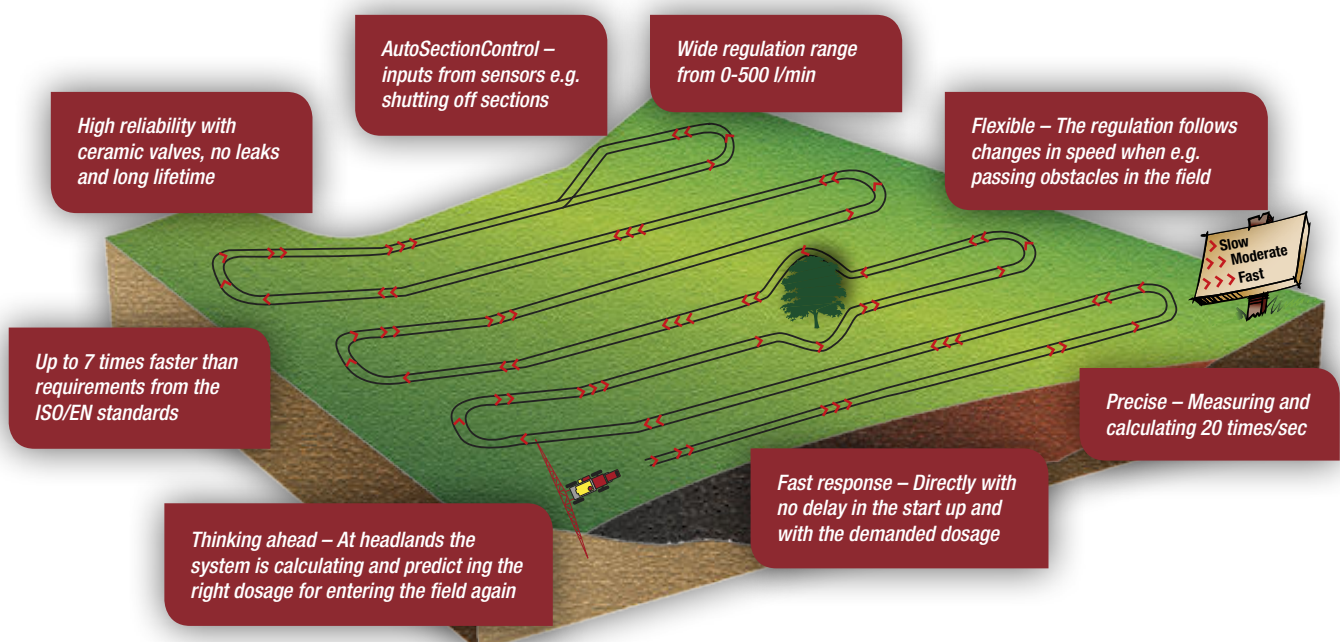

## CUSTOMER BENEFITS:

- ▶ Fully ISOBUS
- ▶ Modular ECU network
- ▶ Unlimited capacity
- ▶ Advanced diagnostic tool
- ▶ Prepared for remote diagnostics
- ▶ Prepared for connectivity

# SmartCom electronic platform



Electronic development is going very fast these days. HARDI is developing a new electronic platform with unlimited capacity to prepare well for the future. The SmartCom is our solution for future demands.

The development of the SmartCom is done together with external partners from the automotive industry. After a long development and testing, the SmartCom platform now ready for implementation. The first machine equipped with SmartCom is the MEGA.

In the beginning the features are more or less similar to the existing MEGA with JobCom.

More new features will follow when the MEGA i version will be launched.

### SmartCom is fully ISOBUS

All SmartCom sprayers are fully ISOBUS sprayers- which will always require an ISOBUS terminal to operate the sprayer.

The SmartCom system is a network of different Electronic Control Units (ECU) and Power Distribution Units (PDU) and user interphases as Terminal, SetBox and Grip. The SmartCom is specifically developed for HARDI and it has his own and modular architecture.



The SmartCom distributes the electronic brain on the sprayer. Meaning that the required software for a certain feature will be placed on one SmartCom ECU, normally where it makes sense to have shorter distances. For example, boom features as end-nozzles are placed on the boom center. While the drawbar steering software of the NAVIGATOR will be placed in the front. But it could be also changed, when on one ECU more space is required. The SmartCom system offers a degree of flexibility and is by this future orientated.

The SmartCom has unlimited capacity by means of adding ECU's – processor capacity can be added. Eg 2-3-4-5... ECUs can be parallel connected. This gives the possibility to develop new application systems, with more functions. And gives also flexibility in updating sprayers by uploading new software.

### In future with far more functions

SmartCom offers the integration of 3rd party electronic ISOBUS features, which makes further developments quicker and specific functions can be integrated in the HARDI application technique easier.

### HARDI ServiceTool for faster diagnostics

The SmartCom has an advanced diagnostic tool, and is prepared for remote diagnostics. The HARDI ServiceTool gives the service staff far more possibilities to service sprayers.

The SmartCom is prepared for connectivity, in the future a telemetric module will give the possibility of data exchange to cloud services.



# HARDI ServiceTool

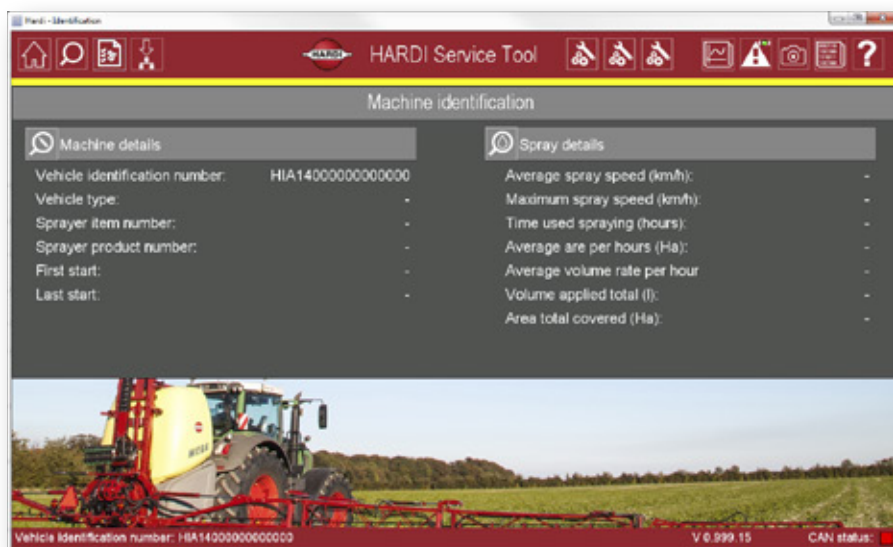

The HARDI ServiceTool has two main functions. First of all it is used for flashing the SmartCom ECUs, the second is to use it as a diagnostic tool in the field.

The new 17 digit VIN number (Vehicle Identification Number) takes care that the sprayer is identified as a unique machine.

## Vehicle Identification Number

With the introduction of the SmartCom a 17 digit VIN number is implemented. The sprayers follow now an international system of identification of machines, which is required for all types of service requirements, mainly published in EU directives.

## Flashing Tool

The flashing tool allows the production team to load the required software into the SmartCom network. For this a PC is connected to a PDU via a specific HARDI SmartLink cable.

All data is stored in relation to the VIN number and the specific order. Everybody with access could then later find out what the software status of a sprayer is including it's history.

## Diagnostic tool

In the field, trained service technicians can connect a PC to the sprayer and receive a machine status report. This connection is done via the HARDI SmartLink.

The HARDI ServiceTool can be used in different ways either to get status reports and do fault finding, or as a flashing tool to

upload new software solution or to install a new app.

## Machine status report

The machine status report is automatically generated when the HARDI ServiceTool is connected to the sprayer. The Diagnostic Trouble Codes (DTC) are directly shown in a table. In this table all codes are listed and also how often this messages has been detected since the last report. The report helps the service staff to get a first overview

## Diagnostic by function

The diagnostic system is advanced and will be extended with more and more sprayers and features. Diagnostic by functions is possible, for example a DF4 system has different sensors which interact with each other and it is useful to see if all works correctly. It is also possible to see which

sensors and wires are demanded for a specific function, which will be helpful for the service staff

If a SmartCom ECU must be replaced, the whole system is flashed again. But also a single ECU could be replaced including the correct software, as the data could be taken from the cloud.

## Cloud system to store data

All data of the SmartCom sprayers is stored on a cloud server. This process runs automatically and it doesn't matter if the service staff is online when he is in connection with the sprayer. In the case of being offline all changes are uploaded to the cloud later, when the PC gets back online.



## CUSTOMER BENEFITS:

- ▶ Can be placed in the way the operator wants
- ▶ Large keys so operation is easier at a distance
- ▶ Logically grouped functions
- ▶ Right hand hold of box eases thumb key work
- ▶ Status diode for operator surveillance of system health
- ▶ Located close to the operator
- ▶ Logical operation without looking at Grip
- ▶ Up to 13 boom sections possible
- ▶ **TWIN, SafeTrack and HeadlandAssist are not options on MEGA**

# Grip and SetBox

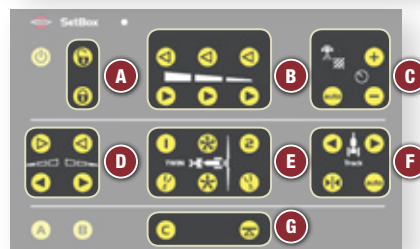
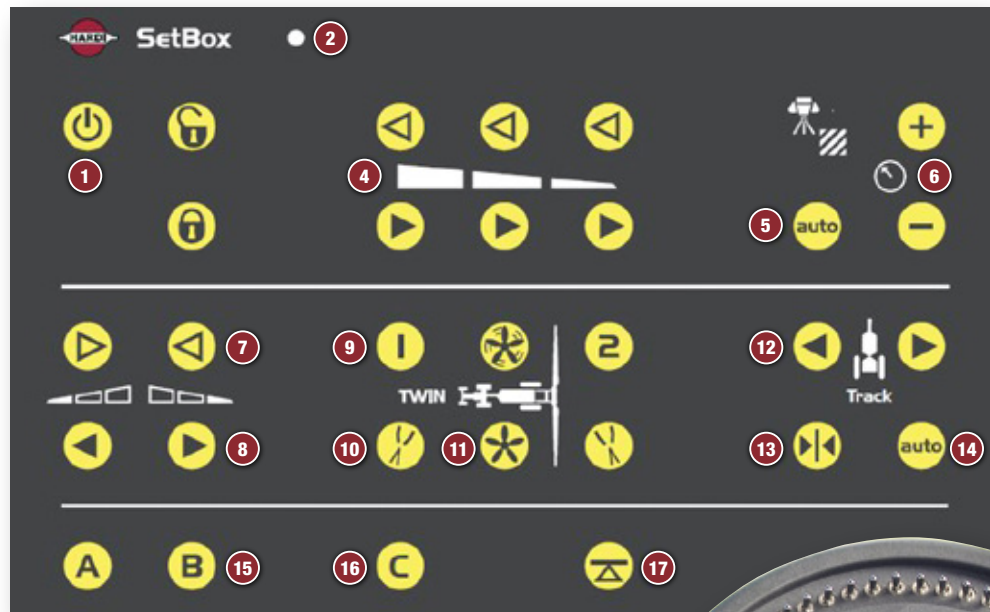

HARDI ISOBUS sprayers always have a Grip and a SetBox.

The SetBox of the SmartCom generation is changed, the Grip is the same and only works in conjunction with HARDI ISOBUS sprayers.

Grip and SetBox are connect to the ISO CAN with one simple splitter cable. The Grip and SetBox have its own software and all components need to have a matching software. The software is updated through the D-connector "C" on the device. Software in Grip and SetBox is adapted to the ISOBUS CAN.

The SetBox controls secondary functions on the sprayer. The keys are larger so even at a distance, operation can be carried out.

The keys are grouped into seven control areas to simplify operator understanding.

The Grip is placed close to the operator as it has the most used functions in a logical layout. Operation is done without having to take one's eyes from the line of travel. It can be attached to most tractor seat arms.

It has internal lighting so the switches and buttons easily can be seen in poor light.

- |   |   |   |   |
|---|---|---|---|
| <ul style="list-style-type: none"> <li>1. Power ON/OFF</li> <li>2. Status diode</li> <li>3. Pendulum controls</li> <li>4. Boom fold controls</li> <li>5. Automatic volume rate</li> <li>6. Manual pressure control</li> <li>7. Foam marker regulation</li> <li>8. Foam marker ON/OFF</li> </ul> | <ul style="list-style-type: none"> <li>9. TWIN presets (n/a)</li> <li>10. Air slot for TWIN (n/a)</li> <li>11. Air volume for TWIN (n/a)</li> <li>12. IntelliTrack manual control (n/a)</li> <li>13. IntelliTrack centering and lock (n/a)</li> <li>14. IntelliTrack automatic (n/a)</li> <li>15. Valve function A-B</li> </ul> | <ul style="list-style-type: none"> <li>16. HeadlandAssist automatic (n/a)</li> <li>17. HeadlandAssist boom centring (n/a)</li> <li>18. Boom section controls (up to 13)</li> <li>19. Main ON/OFF</li> <li>20. Boom tilt</li> <li>21. Boom height</li> <li>22. Boom slant</li> </ul> | <p><b>Keyboard groups:</b></p> <ul style="list-style-type: none"> <li><b>A</b> Pendulum</li> <li><b>B</b> Boom fold</li> <li><b>C</b> Liquid</li> <li><b>D</b> Individual boom fold</li> <li><b>E</b> TWIN</li> <li><b>F</b> Safe or IntelliTrack</li> <li><b>G</b> Extra function</li> </ul> |
|---|---|---|---|



## PRO VHZ 15-18 m

The strong and well-proven three-dimensional PRO boom is the ideal choice for operators looking for small transport width and a boom with flexible working width.



## VPZ 20-28 m

The lattice boom structure ensures a strong and rigid boom; the basis for exact and uniform spray distribution. The nozzles, spray lines and hoses are all well protected within the boom design. The VPZ has integrated AntiYaw dampers on the boom wings.



### CUSTOMER BENEFITS:

- ▶ **Strong and well-proven**
- ▶ **Three-dimensional**
- ▶ **Flexible working width**
- ▶ **Integrated AntiYaw dampers**
- ▶ **PRO VHZ boom:**
  - 18 m - 7 sections
  - 18 m - 6 sections
  - 16 m - 7 sections
  - 15 m - 7 sections
  - 15 m - 5 sections

### CUSTOMER BENEFITS:

- ▶ **Lattice boom structure ensures a strong and rigid boom**
- ▶ **The nozzles, spray lines and hoses are all well protected**
- ▶ **Integrated AntiYaw dampers**
- ▶ **VPZ boom:**
  - 28 m - 9 sections
  - 28 m - 7 sections
  - 27 m - 9 sections
  - 27 m - 7 sections
  - 24 m - 7 sections
  - 21 m - 7 sections
  - 20 m - 5 sections



# BOOMS VPZ Boom Suspension

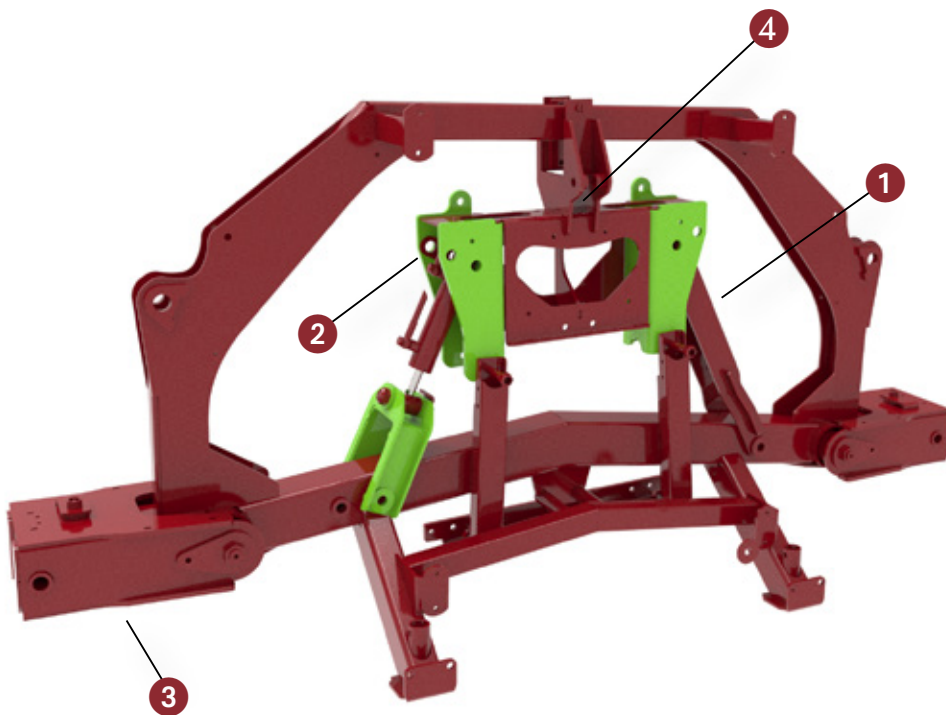

### 1 Trapeze arms

The long trapeze arms provide excellent boom performance in flat and hilly conditions

### 2 Trapeze arms adjustment

The trapeze arms can be adjusted in 4 different positions, adapting the boom suspension to field conditions and terrain.

### 3 AntiYaw

Yaw dampening of horizontal movements is integrated in the inner boom wings.

### 4 Trapeze lock cylinder

The cylinder is standard on all PRO and VPZ booms. With this cylinder the suspension is locked so the boom can be single-side folded.

# VPZ boom wings 20-28 m



## Strong boom wings

The lattice boom structure ensures a strong and rigid boom; the basis for exact and uniform spray distribution. The nozzles, spray lines and hoses are all well protected within the boom design.



### Locking cylinder

Strong locking cylinder on the center for a secure lock of the trapeze when folding.



### AntiYaw

AntiYaw rubber damper on the boom wing.

- 20 and 21 m with one damper.
- 24-28 m with two.



### Hydraulic hook locks

An hydraulically activated hook, locks the inner wing and 1st outer wing together and relieves over-center mechanism.



### Strong folding arms

- Strong adjustment bolts
- The connecting point for the cylinder located close to the turning point
- The folding points between 1st / 2nd and 3rd. outer wings are blocked by hydraulic operated check valves to prevent folding and to keep the boom straight for an even distribution.



### Eccentric bolts

All eccentric bolts in the folding. Bigger nut (outer diameter) and Nord-Lock washers.



### Break-away

A non-directional springloaded break-away system protects the boom from damage. The break-away mechanism is supported by wires and springs.



## CUSTOMER BENEFITS:

- ▶ 3-dimensional
- ▶ SYNTAL boom tubes
- ▶ TRIPLET nozzle holders
- ▶ Spring-loaded break-away
- ▶ Optional
  - BoomFlush
  - Fertilizer equipment

## PRO boom wings



### Breakaway

A non-directional springloaded break-away system protects the boom from damage.



### Integrated folding mechanism

The folding cylinders and the brackets are fully integrated in the boom design.

When unfolded, the boom is totally locked, which ensures a minimum of boom movements and a very accurate application.



### Protected nozzle holders

The TRIPLET nozzle holders are well-protected by the boom structure, ensuring fewer breakdowns and stops in the field.



# Z boom hydraulics

**Requires**

- ▶ 1 double hydraulic outlet
- ▶ No extra double hydraulic outlet for slant necessary.
- ▶ Hydraulic slant is standard on VHZ and VPZ.
- ▶ Box and Grip are used for operation

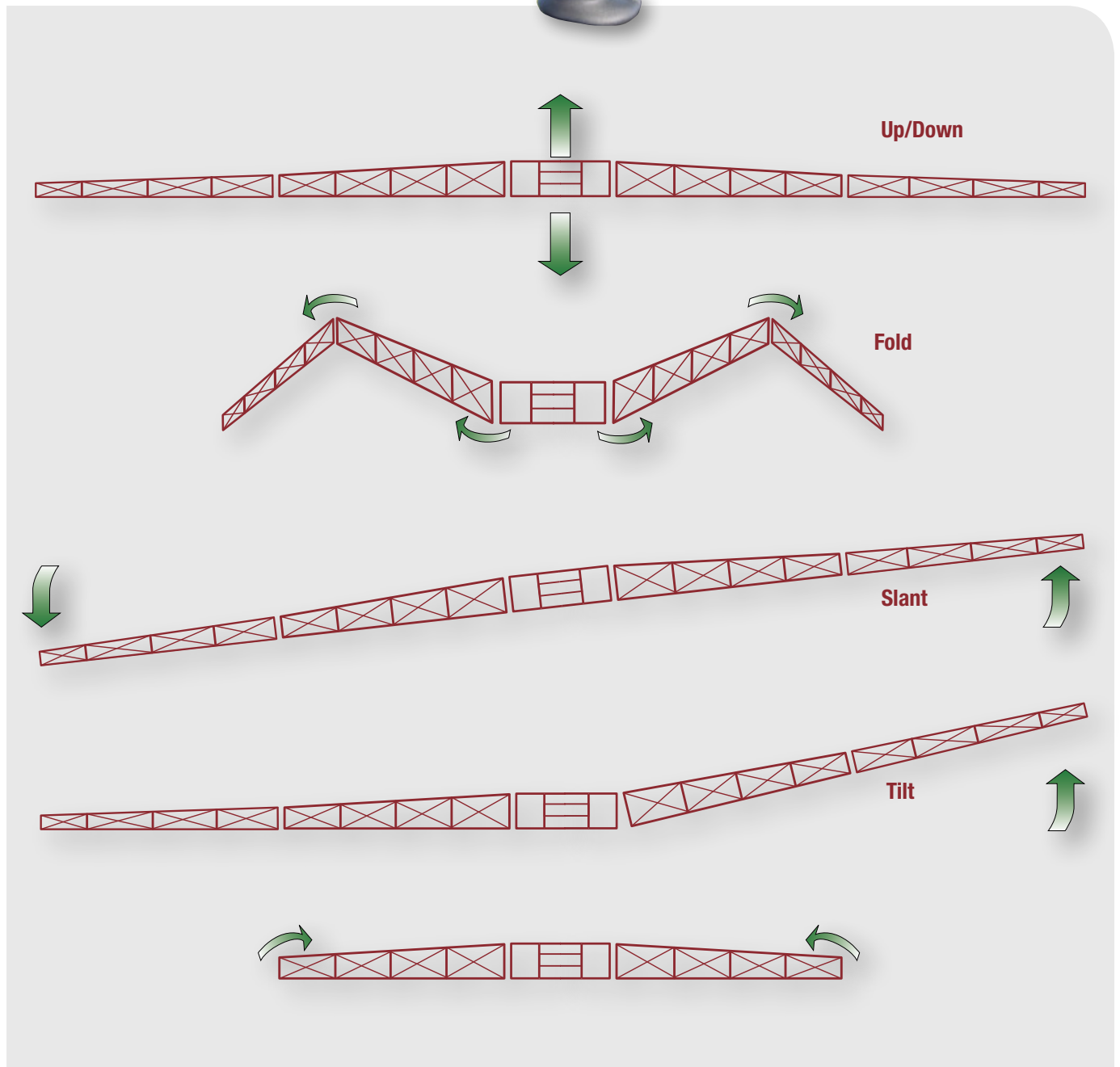

# Y boom hydraulics

**Requires**

- ▶ 1 single hydraulic outlet for up/down
- ▶ 1 double hydraulic outlet for fold
- ▶ 1 double hydraulic outlet for slant (option)
- ▶ Box and Grip are used for operation

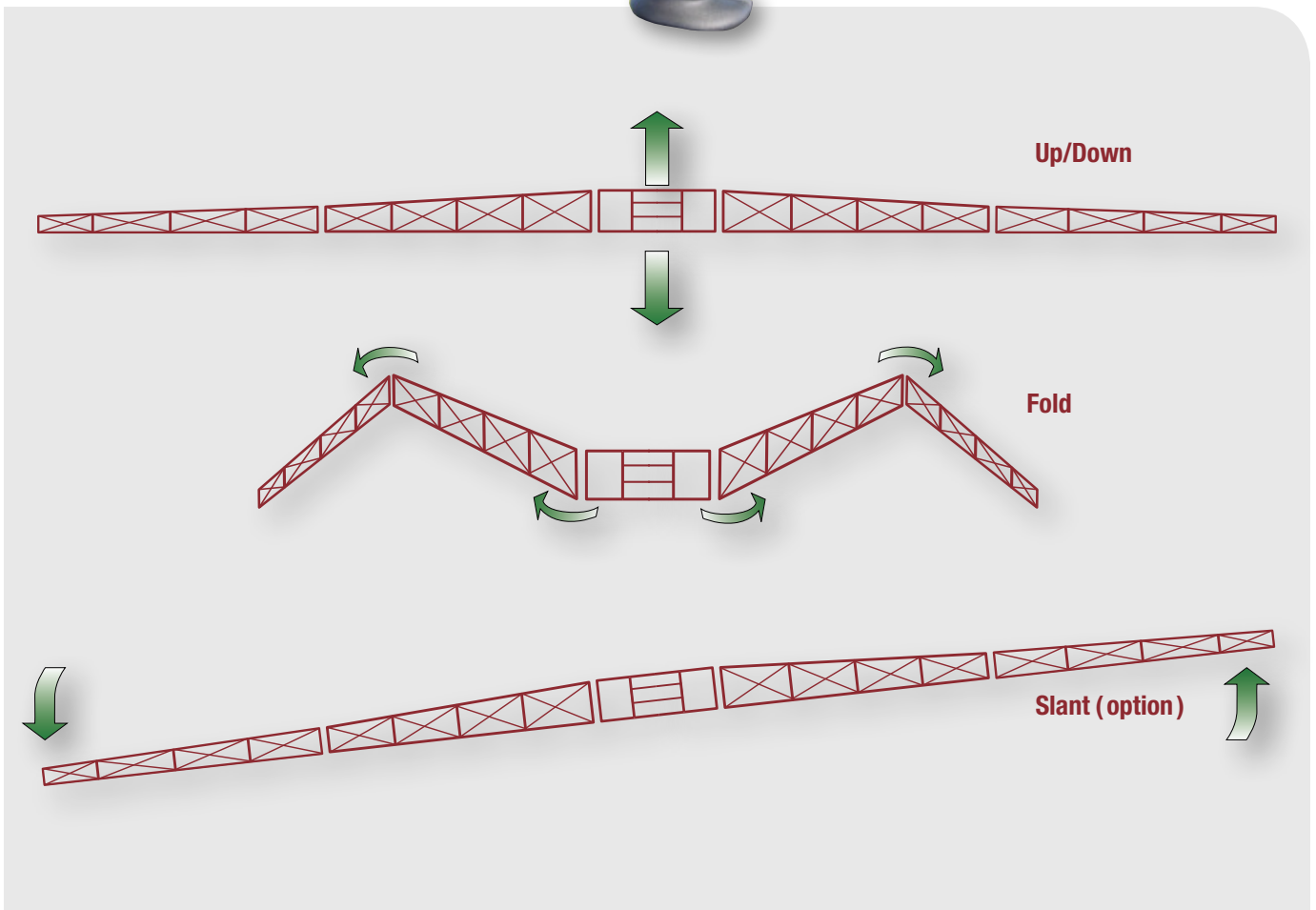

# Boom sections

## Boom sections

The vertically folded VPZ and PRO VHY/VHZ booms have 3, 4 or 5 segments on each boom wing.  
The drawing illustrates how many nozzles each boom section has, and where the booms are folded.

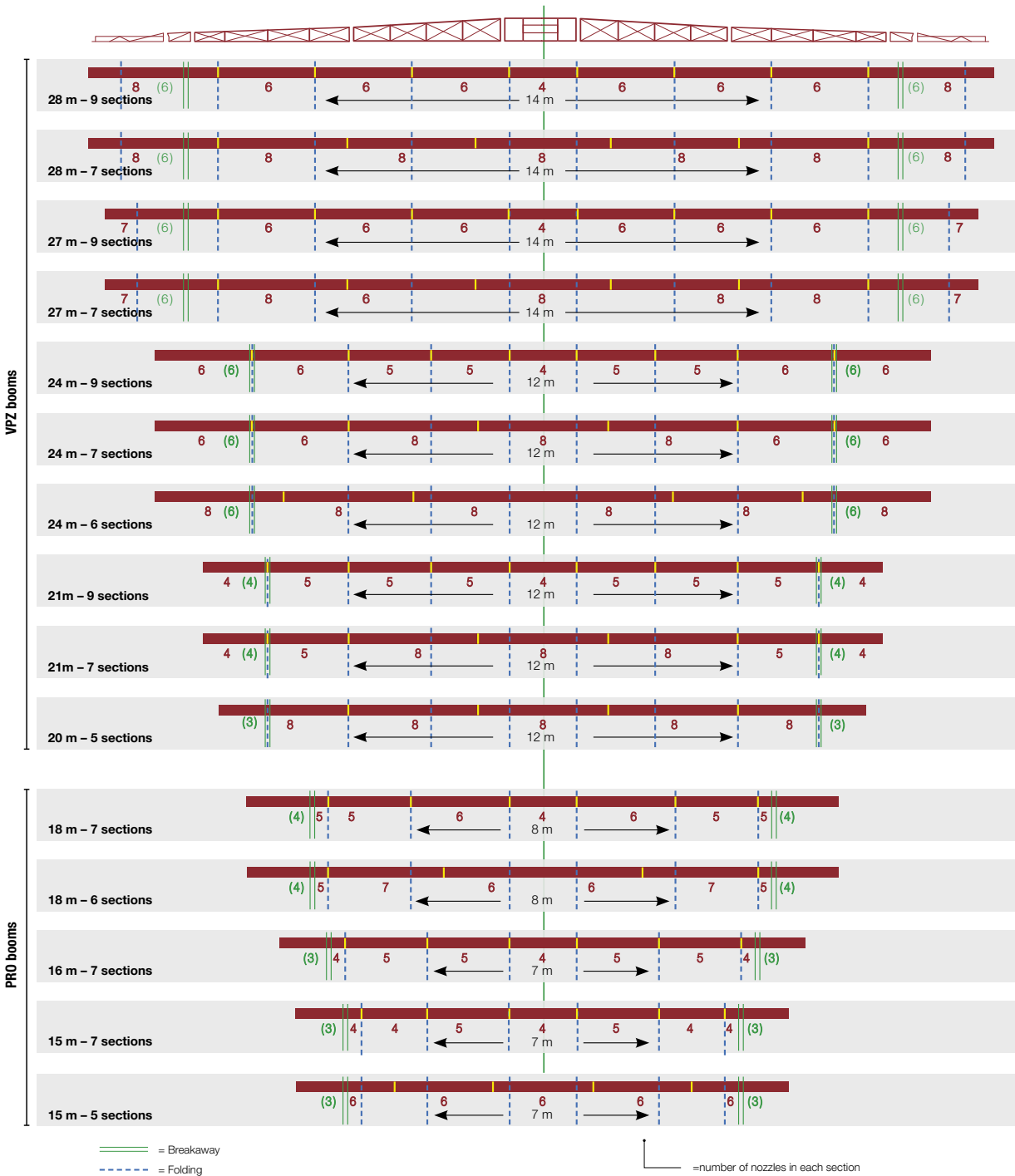



# Boom management systems



## CUSTOMER BENEFITS:

- ▶ **More working hours – without compromises in application quality**
- ▶ **Boom can work in optimum height of 50 cm**
- ▶ **Higher driving speed**
- ▶ **Proven agricultural sensors – robust and reliable**
- ▶ **Less operator stress – boom height is always at optimum**

## The HARDI AutoSlant system will automatically control the boom

This makes the job much easier for the driver, and the result will be a better spray application.

The system is known for the following features:

- ▶ Robust and precise ultrasonic sensors
- ▶ Option to choose between soil, crop or hybrid mode
- ▶ Slant and height correction (AutoSlant)

### AutoSlant

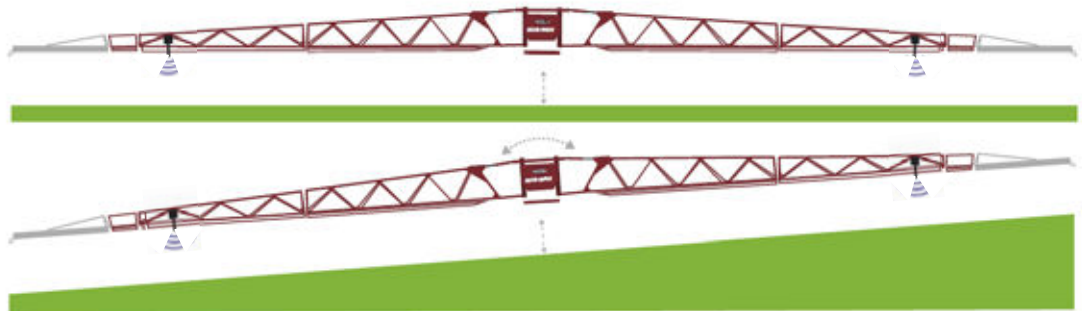

- ▶ AutoSlant is controlling height and slant
- ▶ 2 sensors on boom wing
- ▶ Direct control on sprayer hydraulics
- ▶ Controlled by HC 8600, HC 9600, ISOBUS terminal or Pulse display (with HC6500)
- ▶ VPZ 20 - 28 m

# FrontTank solution



The HARDI FrontTank can be used in different set-ups. Depending on the demands, either a nurse tank to bring more water into the field or a second chemical tank are used. In future a one tank solution will also be offered.

The tank is from Technospra and made in high impact polyethylene and has a liquid free level indicator on top of the tank, which can be seen from the driver seat. The linkage is made for a Cat 2 front linkage.

## Nurse tank solution

The basic tank and frame can be used as a nurse tank solution; it can be connected to a suction valve for FrontTank. In the field the water from the FrontTank can be sucked into the main tank, new chemicals can be added, and the spray job can continue without driving back to the filling station.

## Chemical tank solution

By adding an agitation pump kit and an electric valve kit, the FrontTank can be used as a separate chemical tank. The operator can thus choose from the driver seat, whether he wants to use the spray solution from the FrontTank or from the main tank.

On the pressure side a valve is added to pump liquid from the rear to the FrontTank. On the suction side a remote S93 valve will be added. The return from sections as well as agitation is still active on the main sprayer, so the operator has to control that the main tank is not overfilled.

## Technical data

Tank size (net/gross)	RinseTank	Width (cm)	Height (cm)	Length (cm)	Weight (kg)
1100 / 1180	135	185	110	130	150
1400 / 1500	150	190	115	140	180

## Agitation kit

The agitation kit takes care that the spray solution in the FrontTank is mixed. A 12V driven robust stainless steel centrifugal pump is keeping the mixture homogeneous while the main tank is emptied.

A separate 12 V cleaning pump can be added, so the rinse water in the bigger FrontTank can be used.

The control of the pumps and valves is done by a separate control box, fitting into the SetBox design.



## CUSTOMER BENEFITS:

- ▶ xxx

## PumpFill

The MEGA can be equipped with a PumpFiller Including a 5 m filling hose.

The sprayer is filled by means of the suction capacity of the pump.

The system is 100% self-priming. The Filling device works in combination with the TurboFiller, and simultaneous filling from the TurboFiller and filling device is possible. Coupling is done with a heavy-duty aluminium coupling.

### PressureEmpty

With this system, liquid fertiliser or any other solution can be returned into the storage tank. Coupling is done through the same coupling system as with the PumpFiller, allowing you to use the same hose for filling as well as for emptying. The PressureEmpty is always delivered in combination with the PumpFiller.

Emptying capacity:  
Equal to pump





# External cleaning kit

A cleaning kit can be fitted for safe external cleaning of the complete sprayer in the field.

Several European markets are faced with demands of in-field cleaning of the sprayer. The HARDI system offers a pressure of up to 15 bar, ensuring quick and efficient outside cleaning.



## CUSTOMER BENEFITS:

- ▶ Use of clean water at 15 bar: 25 l/min
- ▶ Use of clean water at 5 bar: 15 l/min
- ▶ Length of 3/8" hose: 20 m
- ▶ Max pressure 15 bar

OPTIONAL EXTRAS

CUSTOMER BENEFITS:

- ▶ No untreated areas at spray start
- ▶ No pesticide sedimentation in the spray lines
- ▶ Positive pressure-based system to ease trouble-shooting



## BoomPrime

The optional BoomPrime is a low pressure circulation system for DELTA booms. The spray liquid can circulate to the nozzles before the actual spraying starts. It prevents sedimentation and permits flushing of the boom lines without spraying onto the ground.

There will still be liquid running through the boom tubes when the distribution valves are closed. A pressure valve in front of the boom sections ensures that the pressure in the sections will be not higher than 0.7 bar, so the non-drip valves will not open.

This is a much simpler and less vulnerable system compared to a vacuum-based system. Leaks in a vacuum system are difficult to locate and even the slightest leak will cause problems.



- 1 Distribution valves
- 2 Pressure sensor
- 3 BoomPrime pressure control valve
- 4 Pressure relief line
- 5 Internal tank cleaning nozzles
- 6 Restrictors
- 7 Sprayer boom

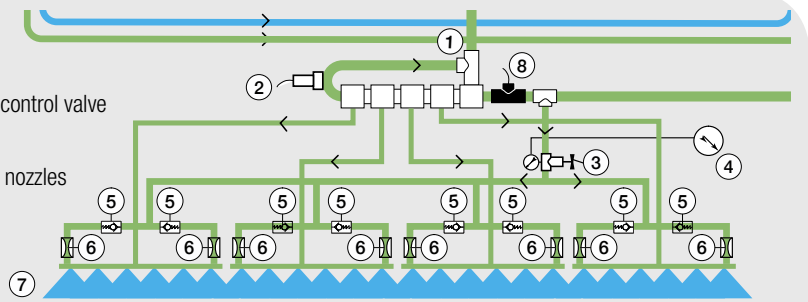

CUSTOMER BENEFITS:

- ▶ Remote dilution
- ▶ High dilution level
- ▶ Operator can stay in cabin

## DilutionKit

The optional DilutionKit system allows the operator to flush and rinse the liquid system from the driver seat.

### Remotely controlled

With the DilutionKit mounted, the liquid system can still be operated from the WorkZone. The operator controls the DilutionKit from the SetBox.

### Tank dilution or BoomFlush

The operator can choose between only flushing the boom lines, or a tank rinse with tank flush nozzle. All return lines and the agitation will be flushed when spraying out the diluted liquid from the main tank. The boom flush function can be used when the main tank is still filled with spray liquid and the spray job must be stopped due to bad weather conditions. Also at the end of a complete rinse process, the work is stopped by a boom flush to make sure that there is clean water in the boom lines.

### High dilution level

The number of dilution steps is under the operator's control. With every extra dilution step the chemical concentration in the residues is diluted.



So if the dilution process is done in more steps and with smaller portions, the system will be better rinsed than if only one rinse takes place. The operator can also save rinse water for outside cleaning or cleaning of extra equipment like the TurboFiller.

### Easy operation

The DilutionKit makes the daily rinse of the spraying system easy, effective, quick and safe. The sprayer can be parked with a low chemical concentration. Also the operator contamination is reduced because he does not have to leave the cab for cleaning the sprayer. A complete cleaning of the liquid system still demands a proven operation of the complete liquid system.



# End-nozzle kit

End-nozzle kit is also in the price list and we need half a page of this. But I have to find a good photo

An extra angled single nozzle holder is added on the boom tube on the break-away. If the end-nozzle is activated the last nozzle is switched off and the angled nozzle is activated.

The end-nozzle kit takes care that no spray is placed outside the field boundary.





CUSTOMER  
BENEFITS:

- ▶ In the WorkZone  
2 separate stores  
Protected
- ▶ Widest  
dimensions:  
W: 52 cm  
H: 30 cm  
D: 29 cm

# SafetyLocker



The SafetyLocker is assembled on the left side above the TurboFiller. It can be used for storage of gloves and mask in the working zone.

The SafetyLocker has 2 separate parts one for clean the other for dirty equipment.

A SafetyLocker is an obligatory feature following the new ISO 4254-6 safety standard.



# HARDI 464 pump

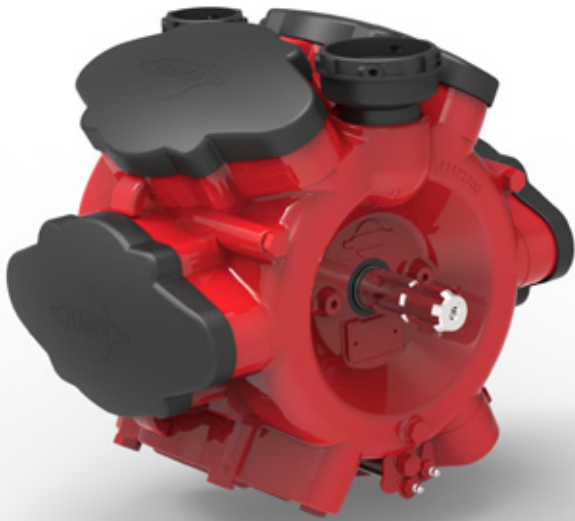

The MEGA liquid system is driven by the robust grease-lubricated HARDI diaphragm pump.

HARDI 464 pump are available for the MEGA as optional extras.

OPTIONAL EXTRAS

## InLine Filters



To avoid blocking of nozzle filters when working with low volume rates or to eliminate the need for nozzle filters, the MEGA can be equipped with the easy-to-service In-Line filters. The In-Line filters are placed on the center section. On VPZ booms InLine filters are standard

## Transport wheels



### Transport wheels

4 heavy duty rollers can be assembled as optional. This wheels are removable.

The front rollers can rotate to make the moving easier

## Boom Lights



LED lamps are placed behind the spraydouche and gives a good overview of blocked nozzles. The lamps are in a design which makes it possible to place them in the boom structure protected for damage if the boom hits the ground. The light is activated from the cabin.

- ▶ 2 LED lamps 15 - 21 m
- ▶ 4 LED lamps 24 - 28 m
- ▶ Positioned under and behind the nozzles



# HC 7500, HC 8600, HC 9600

OPTIONAL EXTRAS



Different ISOBUS terminals can be chosen. More informations about terminal are in the electronic product guide.

## AirRide suspension



### The optional AirRide suspension

Air dampers will absorb movements of the sprayer. The dimensions of the air dampers ensure that they do not get over-compressed when the tank is full, which will make them last longer.

During road transport the MEGA and consequently the boom will be less stressed.

In field conditions the boom suspension will work better. This way the boom can be run in optimum height over the crop.



# Nozzles

## HARDI spray nozzle selection guide

The HARDI ISO nozzle series is the most complete nozzle series on the market. This full range ensures that nozzles of all relevant sizes are available for all spray jobs.



### HARDI ISO – Standard-Flat Fan nozzle (F)

The essential, multi-purpose Flat Fan nozzle. Ensures maximum coverage and superior uniform distribution in most situations. These nozzles can be recommended for all pesticide applications.



### HARDI ISO – LowDrift-Flat Fan nozzle (LD)

LowDrift nozzles are recommended when optimal spraying conditions cannot be achieved yet spraying cannot be postponed. These nozzles have less Very Fine (driftable) droplets.



### HARDI QUINTASTREAM 5-hole nozzle (Q)

For applying liquid fertilizer. This new (patent pending) HARDI designed nozzle series can uniquely ensure a uniform distribution at boom heights from 35-100 cm. The easy way to turn your sprayer into a high precision fertilizer applicator.



### HARDI INJET – Air Inclusion nozzle (INJET)

The mix of air and water gives these nozzles a very coarse droplet spectrum, which will remarkably decrease the risk of drift. Recommended for very wind tolerant applications of soil applied and systemic pesticides.



### HARDI ISO MINIDRIFT – Air Inclusion nozzle (MD)

HARDI MINIDRIFT makes it possible to change from Medium to Coarse/Very Coarse just by turning the TRIPLET – pressure and volume rate will stay the same – and the spray job can be finished even at higher wind speeds.



### HARDI MiniDrift DUO

The HARDI MINIDRIFT DUO nozzle can be used for spraying at sub-optimal weather conditions, when spraying cannot be postponed. The MINIDRIFT DUO nozzle will at low pressures reduce drift to a minimum.

This compact flat spray air injector nozzle offers droplet spectrum from medium to very coarse; safe for drift control but without risking poor coverage and deposition on leaves. The two angled fans spraying 30° forward and backward, and impacts on target deposit compared to normal air injector nozzles.

ISO number/colour					l/min	l/ha at km/h							
	Spray quality					6	7	8	10	12	15	20	25
0075-Pink	F	–	–	–	0.30	60	51	45	36	30	24	18	14
01-Orange	F	M	–	VC	0.40	80	69	60	48	40	32	24	19
015-Green	F	M	C	VC	0.60	120	103	90	72	60	48	36	29
02-Yellow	F	M	C	VC	0.80	160	137	120	96	80	64	48	38
025-Lilac	M	M	C	VC	1.00	200	171	150	120	100	80	60	48
03-Blue	M	C	C	VC	1.20	240	206	180	144	120	96	72	58
04-Red	M	C	VC	VC	1.60	320	274	240	192	160	128	96	77
05-Brown	M	C	VC	VC	2.00	400	343	300	240	200	160	120	96
06-Grey	C	–	–	VC	2.40	480	411	360	288	240	192	144	115
08-White	C	–	–	VC	3.20	640	549	480	384	320	256	192	154
10-Light blue	C	–	–	–	4.00	800	686	600	480	400	320	240	192
15-Light green	–	–	–	–	6.00	1200	1029	900	720	600	480	360	288

**Spray quality:** F = Fine, M = Medium, C = Coarse, VC = Very coarse, S = Solid stream

*All values are at 3 bars pressure*

**Pressure range:** For F, LD, MD and Q is 1.5 to 5 bar (1.5 to 3 bar recommended) and for INJET 3 to 8 bar (4 to 7 bar recommended).

# HARDI Service

## Service

HARDI machinery is serviced by a grid of specially educated service technicians. HARDI is aware of the importance of supplying knowledge to the buyers along with the sprayers. This increases the value of the sprayer for the end-user. To emphasize HARDI's investment in spreading know-how about the technical and applicational aspects of the sprayers, HARDI founded the "HARDI Academy" in 2004. HARDI Academy offers a wide range of courses, from 1st level technician to high specialist level. The strategy followed is still that of significant investments in educating our customers and their customers.

## Extensive user manuals

Along with the HARDI Sprayer is an extensive user manual, instructing the user in all relevant matters to get the most of the new machine. The manual covers all light service issues and user instructions for the entire machine, including the electronic and computing devices. Also included is service manuals for technical service.

## Spare parts

Availability of spare parts is a crucial issue to secure the reliability of the HARDI sprayer. Some parts are wearing parts, which need to be replaced as a consequence of using the sprayer. Other parts are suddenly needed due to collisions and other acute mishaps.

The spare parts stock carried by any HARDI distributor is backed up by central spare parts stocks, carrying all fast and most slow moving parts. This chain of supply secures a smooth and reliable service to HARDI machines worldwide. HARDI spare parts are available all over the world, and most areas are covered within 24 hours. Find the complete HARDI spare parts catalogue on: [www.hardi-international.com](http://www.hardi-international.com).

Original HARDI spare parts are, of course, manufactured under the same strict tolerances and quality demands as the complete machines. This goes for wearing parts, that are mostly easily replaced, as well as the complex hydraulic and mechanical parts.





# Technical specifications

Tank size	1200	1500	1800	2200
Pump 364 (194 l/min)	•	•	•	•
Pump 464 (280 l/min)	•	•	•	•
RinseTank	170 l	170 l	170 l	170 l
CleanWater tank	20 l	20 l	20 l	20 l

**Weight, kg (empty)**

15 m – 16 m PRO	1256	1268	1312	1327
18 m PRO	1314	1326	1370	1385
20 m VPZ	1379	1391	1435	1450
21 m VPZ	1389	1401	1445	1460
24 m VPZ	1409	1421	1465	1480
27 m VPZ	N/A	1521	1565	1580
28 m VPZ	N/A	1531	1575	1590

**Measurements, cm**

	A x B x C	A x B x C	A x B x C	A x B x C
15 m – 16 m PRO	151 x 234 x 288	151 x 234 x 288	221 x 234 x 288	221 x 234 x 288
18 m PRO	151 x 234 x 315	151 x 234 x 315	221 x 234 x 315	221 x 234 x 315
20 m VPZ	172 x 234 x 292	172 x 234 x 292	242 x 234 x 292	242 x 234 x 292
21 m VPZ	172 x 234 x 292	172 x 234 x 292	242 x 234 x 292	242 x 234 x 292
24 m VPZ	174 x 234 x 327	174 x 234 x 327	244 x 234 x 327	244 x 234 x 327
27 m VPZ	N/A	174 x 234 x 328	244 x 234 x 328	244 x 234 x 328
28 m VPZ	N/A	174 x 234 x 328	244 x 234 x 328	244 x 234 x 328

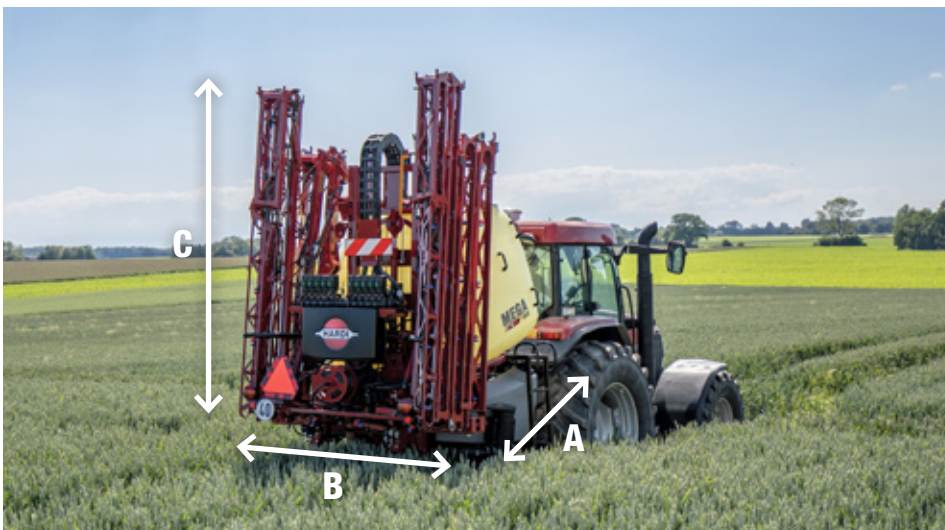

**A** = Total length in cm   **B** = Maximum transport width in cm   **C** = Total height in cm



